

**Section 1**

Re: 05X50BOX

Report Number: HM 9498  
Date of Report: May 19, 2017  
Date of Test: April 14, 2017

Test performed by: **Advanced Packaging Technology Laboratories, Inc.**  
200 Larkin Drive, Unit H  
Wheeling, IL 60090

Test conducted for: **Demex International, Inc.**  
7144 Dummyline Rd  
Picayune, MS 39466

**Attention: Chris Windham**

Items tested: One (1) sample set of combination packages intended for the transport of hazardous articles.

Box: Natural wood cleated box with removable wood cover

Approximate size (O.D.): 51.625" x 6.875" x 7.625"

Inner package: Simulated Article (fiberboard tube filled with inert media)

See descriptions in body of report.

Nominal tare weight: 22.15 lbs.  
Nominal gross weight: 73.9 lbs.

Object of test: Design qualification testing to determine compliance with applicable sections of 49 CFR pertaining to the transport of dangerous goods – Packing Group II.

Findings: As submitted and tested, this package design was considered to comply with noted requirements.



**4C1 / Y33.5 / S / 17\***  
**USA / +BR10305**

Not to scale, for example purposes only.  
\*indicates last two digits of year of manufacture as per 178.503 (a) (6)

Expiration: This package certification expires 2 year(s) from the date of this report.

  
**Dzintars Petersons**  
Sr. Project Engineer

  
**Rafael Cameron**  
UN/DOT Department Manager

**Table of Contents**

Section 1	Cover Page
Section 2	Package Description
Section 3	Testing Procedures and Results
Section 4	Calculations
Section 5	Drawings and Pictures of Packaging Components
Appendix A	Test Equipment and Instrumentation
Appendix B	Definitions / Abbreviations / Conversions

## Section 2 - Package Description

### Wood Box

Package identification:	UN 4C1			
Manufacturer:	Erwin Containers Burleson, TX 76028			
Box style:	Wood Box			
Material:	Natural wood heat treated pine approximately 0.75" thick			
Part number:	05X50BOX			
Spec:	Not indicated			
<b>Outer dimensions</b>				
Length	51.625	in	1311.27	mm
Width	6.875	in	174.62	mm
Height	7.625	in	193.67	mm
<b>Inner dimensions</b>				
Length	47.125	in	1196.97	mm
Width	5.375	in	136.52	mm
Height	5.375	in	136.52	mm
<b>Length panel dimensions</b>				
Length	51.625	in	1311.27	mm
Width	5.250	in	133.35	mm
<b>Width panel dimensions</b>				
Length	5.500	in	139.70	mm
Width	5.500	in	139.70	mm
<b>Top and Bottom panel dimensions</b>				
Length	50.250	in	1276.35	mm
Width	6.875	in	174.62	mm
<b>Top braces none</b>				
Length		in	0.00	mm
Width		in	0.00	mm
<b>Side Cleats (4 cleats)</b>				
Width	1.875	in	47.62	mm
Height	7.625	in	193.67	mm
<b>Hardware</b>		<b>Quantity</b>	<b>Dimensions</b>	
Large Nail (clinched and coated) 7d (2.2 g ea)		0	2.25" x 0.113"	
Medium Nail (clinched and coated) 6d (2 g ea)		74	2" x 0.113"	
Small Nail (clinched and coated) 3d (.7 g ea)		10	1.25" x 0.08"	
Screw Phillips drywall countersunk (2.3 g ea)		6	1.5 "	
Hinges		n/a		
Hasp		n/a		
Swivel		n/a		
Method of construction:	Assembled with above hardware			
Gram weight:	7612.0 grams (16.78 lbs.) – Tare weight includes all nails			
Quantity:	One (1)			
Unique features:	All components compliant to HT142, Box had rope handles			

## Cover

Manufacturer:	Erwin Containers Burleson, TX 76028			
Material:	Natural wood 0.75" thick, pine HT142			
Part number:	05X50BOX LID			
<b>Overall dimensions</b>				
Length	50.250	in	1276.35	mm
Width	6.875	in	174.62	mm
Height	75.000	in	1905.00	mm
<b>Top panels</b>				
Length		in	0.00	mm
Width		in	0.00	mm
<b>Top crossers (none)</b>				
Length		in	0.00	mm
Width		in	0.00	mm
<b>Hardware</b>		<b>Quantity</b>	<b>Dimensions</b>	
Description and method of construction:	One piece wood			
Gram weight:	2275.6 grams			
Quantity:	One (1)			
Unique features:	No fasteners only hole for screw closures			

## Simulated Article

Manufacturer:	DEMEX International Inc. Picayune, MS 39466			
Material:	Filled with inert media			
Method of construction:	Fiberboard (Kraft) tube			
Part number:	N/I			
<b>Outer dimensions</b>				
Diameter	5.250	in	133.35	mm
Height	43.875	in	1114.42	mm
Gram weight:	Approximately 51.75 lbs.			
Quantity:	One (1)			
Orientation:	upright			

### Cushioning

Manufacturer:	ULINE, 12575 Uline Dr., Pleasant Prairie, WI 53158			
Inner packaging style:	Bubble wrap			
Material:	polyethylene			
Method of construction:	As supplied			
Part number:	S-2501P			
<b>Outer dimensions</b>				
Length	12.000	in	304.80	mm
Width	12.000	in	304.80	mm
Height	0.117	in	2.97	mm
Gram weight:	11.3 grams per sheet			
Quantity:	13 sheets minimum or as needed			
Orientation:	See closure instructions			
Unique features:	As needed			

### Closing Methods

Sealing method:	Contraction Screws
Manufacturer:	Bulldog Hardware
Part number:	#8 1.5"
Type:	Screw Phillips drywall countersunk (2.3 g ea)
Size:	2.3 g x 1.5"
Orientation:	Centrally located on side wall, 1.125" from edge on ends and centrally located length wise.
Gram weight:	Included in box
Quantity:	Six (6) Total

### Additional Test Information

Overall tare weight of package:	22.15	lbs	10.04	kg
Test contents:	Articles, supplied by customer			
Density	51.75 lbs/box			
Test weight of package:	73.9	lbs	33.51	kg
Authorized package gross weight:	73.9		lbs.	

### Third-Party Laboratory Assembly and Closure Instructions

1. Gather one (1) of the specified wood boxes
2. Place simulated articles centrally inside box
3. Place bubble wrap around all sides of article and fill all void spaces with bubble wrap.
4. Centrally located cover and then screw in place. Screws driven till they are counter sunk flush into the wood. (1.125" from edge), into the wall on end sides, two (2) screws each. Additionally there are two screws driven one on each side mid way length wise

### Equipment used to prepare the packages for testing

- Torque tester- Secure-Pak, digital, #D-928
- Tape dispenser- Uline, 2" wide hand-held, #H-150
- Tape dispenser- Uline, 3" wide hand-held, #H-596
- Induction sealer- Jores Tech, set @ 80° C, #IND-100HA
- Glue gun- 3M Industrial, set @ 220° F, # 75S9
- Poly bag sealer- MEC roller style, set @ 410° F, #ME-803HW
- Paint can sealer, cam action seals plugs by Freund # 7855
- Hand-applied
- Cut, moistened, & applied by hand
- Other:

### Customer or Filler's (End-User's) Assembly and Closure Instructions

Same as Third-Party Laboratory Assembly and Closure Instructions.

## Section 3 – Testing Procedures and Results

### Package Preparation – For All Testing

The packages were filled to a minimum of 95% full (see Section 4 for calculation). The inner packaging was inserted as described in the closure instructions.

### Package Panel Orientation – For All Test setups

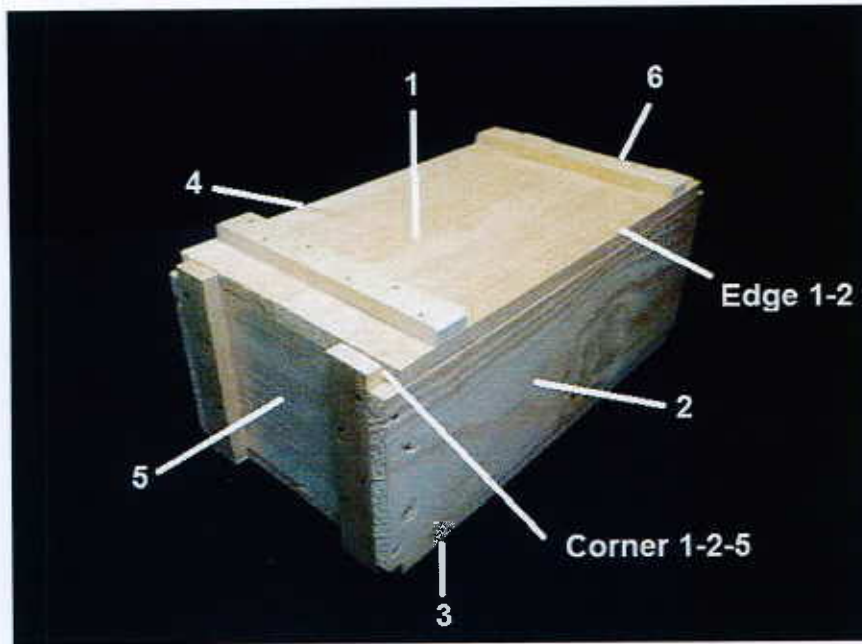

\*Photo for orientation purposes only, not actual box tested

## Drop Test

Test Method: 49 CFR 178.603

Number of packages tested:	Five (5)	
Drop height:	1.2	meters

(Calculation for the drop height is provided in Section 4)

Testing was conducted to certify the package for Packing Group:	II
Simulated articles – boxes filled with inert media	73.9 lbs.

## Conditioning

The packages were conditioned to 50% +/- 2% relative humidity at 23 °C +/- 2% in accordance with 49 CFR 178.602, 178.603(c). The packages were conditioned for at least 24 hours to ensure the package and contents were at the proper temperature prior to testing. Drop testing was conducted approximately 2 minutes after removing the test package from the conditioning chamber. The temperature of the test media was checked during the inspection process.

## Results

Box Number	Test Package Weight		Orientation	Results & Description
1	73.9	lbs.	Flat on Bottom-Face 3	Pass / No visible damage or leakage. No change in appearance, looks like new.
2	73.9	lbs.	Flat on Top-Face 1	Pass / No visible damage or leakage. No change in appearance, looks like new.
3	73.9	lbs.	Flat on Long Side-Face 2	Pass / No visible damage or leakage. No change in appearance, looks like new.
4	73.9	lbs.	Flat on Short Side-Face 5	Pass / No visible damage or leakage. No change in appearance, looks like new.
5	73.9	lbs.	Corner-Corner 1-2-5	Pass / No leakage. Some pulling away of the corner panels, nails held box together. All material contained, safe for further transport.

## Pass/Fail Criteria

A package is considered to successfully pass the drop tests if for each sample tested: There is no damage to the outer packaging likely to adversely affect safety during transport, there is no leakage of the filling substance from the inner packaging and any discharge from a closure is slight and ceases immediately after impact. After the test was completed, the test samples were opened and inspected for any damage; samples were placed horizontally during inspection to check for any leaks, spillage, or loss of contents (duration of five minutes minimum). Package was used from previous test? Yes or No:

Package # 1	Yes	Package also used in stacking test and vibration tests.
Package # 2	Yes	Package also used in stacking test and vibration tests.
Package # 3	Yes	Package also used in stacking test and vibration tests.
Package # 4	No	Not applicable.
Package # 5	No	Not applicable.



## Stacking Test

Test Method: 49 CFR 178.606

Free standing:	<input checked="" type="checkbox"/>	Group stack:	<input type="checkbox"/>	Individual stack:	<input checked="" type="checkbox"/>
Packages tested:	Three (3)	Test duration:	24	hours	

Group stack description: Not used.

The packages were conditioned in accordance with 49 CFR 178.602(d) to 50% +/- 2% relative humidity at 23 °C +/- 2 °C for at least 24 hours.

Stacking test weight:	1075.00	lbs.	487.52	kg
Rounded up from:	1070.81	lbs.	485.62	kg

See Section 4 for Calculation.

The stacking test load was applied to the top of the packages by loading each package with the stacking test weight (above) and the weight was maintained for 24 hours.

### Results

Package #	Pass / Fail	Description of Results
1	Pass	No damage or leakage. No change in appearance, looks like new.
2	Pass	No damage or leakage. No change in appearance, looks like new.
3	Pass	No damage or leakage. No change in appearance, looks like new.

Note: Stacking stability was not assessed since a guided load test was not performed.

### Pass/Fail Criteria

No test sample may leak. There must be no leakage of the filling substance from the inner receptacle, or inner packaging. No test sample may show any deterioration which could adversely affect transportation safety or any distortion likely to reduce its strength, cause instability in stacks of packages, or cause damage to inner packaging's likely to reduce safety in transportation. After the test was completed, the test samples were opened and inspected for any damage; samples were placed horizontally during inspection to check for any leaks, spillage, or loss of contents (duration of five minutes minimum).

Package was used from previous test? Yes or No:

Package # 1	Yes	Package also used in vibration test
Package # 2	Yes	Package also used in vibration test
Package # 3	Yes	Package also used in vibration test

## Vibration Standard

Test Method: 49 CFR 178.608 using ASTM 999-08 (Method A1)

Test contents of inner containers:	Simulated articles – boxes filled with inert media
Number of packages tested:	Three (3)

The packages were conditioned in accordance with 49 CFR 178.602(d) to 50% +/- 2% relative humidity at 23 °C +/- 2 °C for at least 24 hours. The samples were placed on the table and the steel shim (2" wide x 10" long by 1/16" thick, steel) was used (inserted a minimum of 4" under the test sample and along the full length of the box on all sides) to assist in adjusting the frequency.

Duration:	1 hour			
Frequency:	4.3	Hz	258	rpm

## Results

Package #	Pass / Fail	Description of Results
1	Pass	No damage or leakage. Slight scuffing on bottom of package.
2	Pass	No damage or leakage. Slight scuffing on bottom of package.
3	Pass	No damage or leakage. Slight scuffing on bottom of package.

## Pass/Fail Criteria

A packaging passes the vibration test if there is no rupture or leakage from any of the packages. No test sample should show any deterioration which could adversely affect transportation safety or any distortion liable to reduce packaging strength. After the test was completed, the test samples were opened and inspected for any damage; samples were placed horizontally during inspection to check for any leaks, spillage, or loss of contents (duration five minutes minimum).

Package was used from previous test. Yes or No:

Package # 1	Yes	Package also used in stacking test.
Package # 2	Yes	Package also used in stacking test.
Package # 3	Yes	Package also used in stacking test.

**Section 4 - Calculations**

**Empty Package Weight**

Box :	7612.0	grams	7.612	kg	16.781	lbs
Cover:	2275.6	grams	2.275	kg	5.016	lbs
Inner packaging:	146.9	grams	0.146	kg	0.323	lbs
Closures:	13.8	grams	0.013	kg	0.030	lbs
Total:	10048.3	grams	10.048	kg	22.152	lbs

**Filled Package Weight**

Simulated article weight:	51.750	lbs	23.46	kg
Test package gross weight:	73.900	lbs	33.51	kg

**Drop Test Height**

Specific gravity of certification <input checked="" type="checkbox"/> Not adjusted for specific gravity*	Simulated articles	
Packing group of certification	II	
Drop height: specific gravity x 1.0 =	1.2	meters

\* Drop height based on actual product/weight.

**Marked Weight to Accommodate Actual Product**

Weight of fill	51.75	lbs	23.46	kg
Total tare weight	22.152	lbs	10.04	kg
Weight of fill + Tare weight	73.902	lbs	33.51	kg
Marked weight rounded down	73.9	lbs	33.5	kg

**Certified Weights**

Certified actual product weight	51.750	lbs	23.46	kg
Certified product weight + Tare weight	73.9	lbs	33.51	kg
Certified gross weight (rounded down)	73.9	lbs	33.5	kg

**Stack Test Weight**

Load = (n-1)[W+F]

Where:

N = Number of containers to reach 3 meters

W = Tare weight of all packaging material

F = weight of fill

Actual product

Package height	7.625	inches	=	19.36	cm
Stack height = 3.0 meters = 118.11 inches	118.11	/	7.625	=	15.49 Boxes high
Stack height - 1 x marked weight (above)		14.49	x	73.9	lbs
= Calculated stack weight	1070.81	lbs		485.62	kg
= Actual stack weight	1075.00	lbs		487.52	kg

Section 5 - Drawings and Pictures of Packaging Components

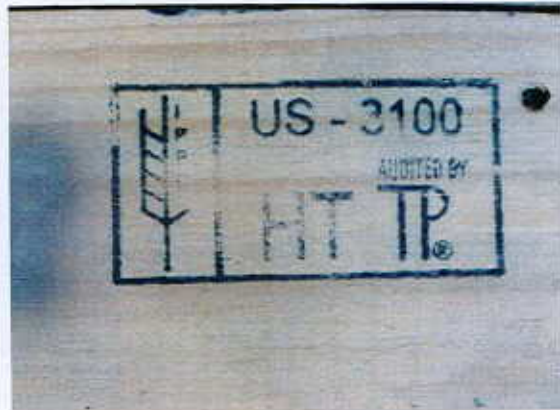





# Box Drawing

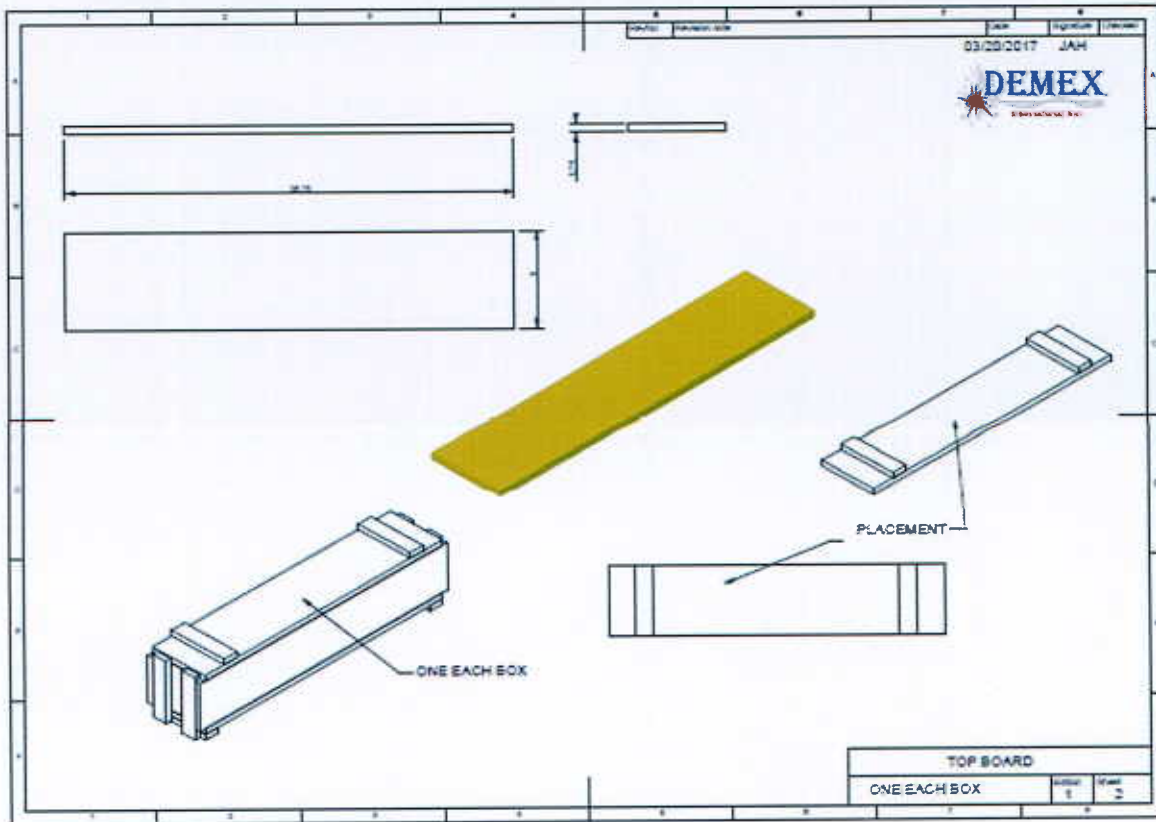
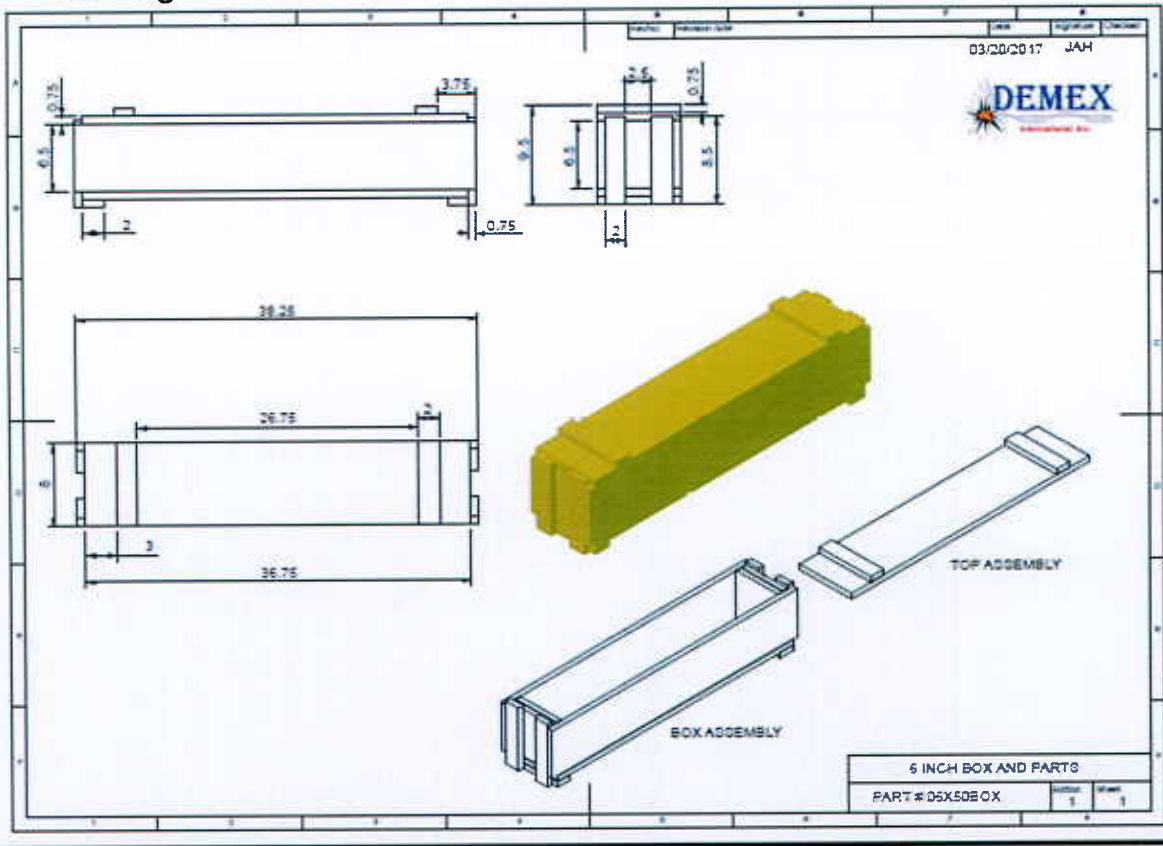



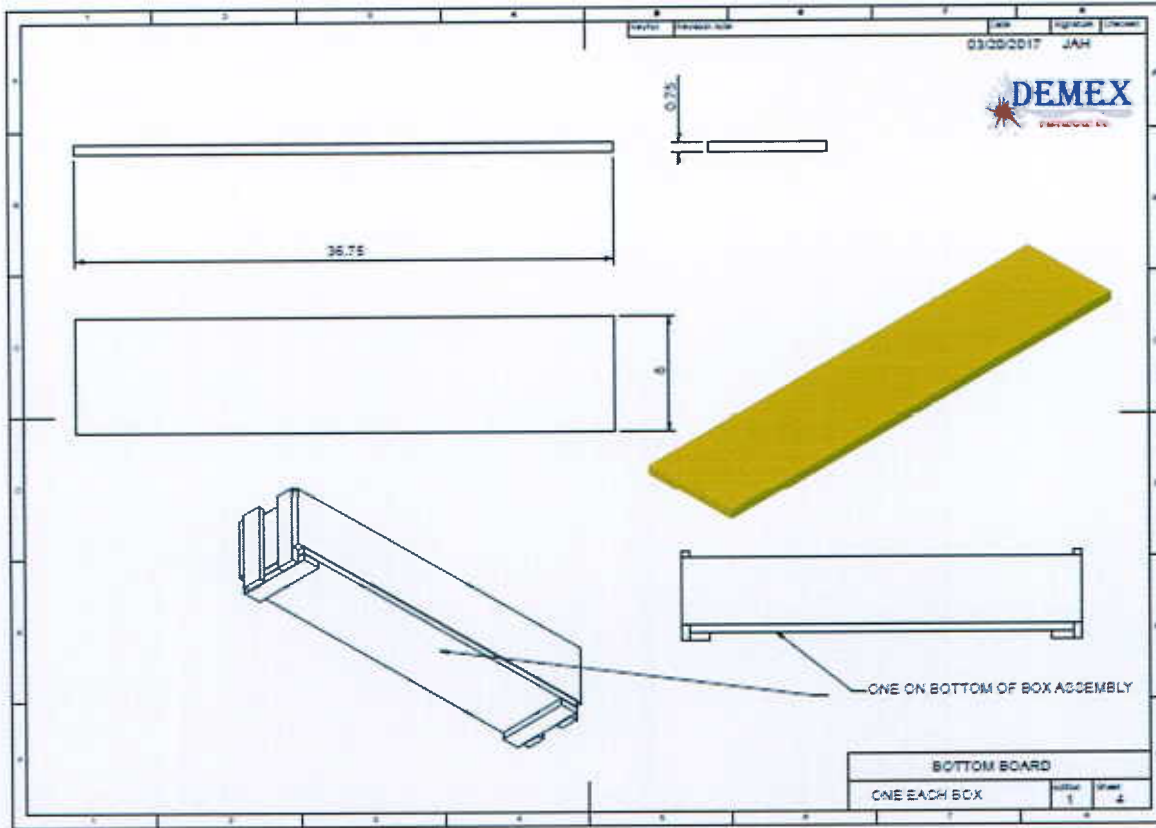

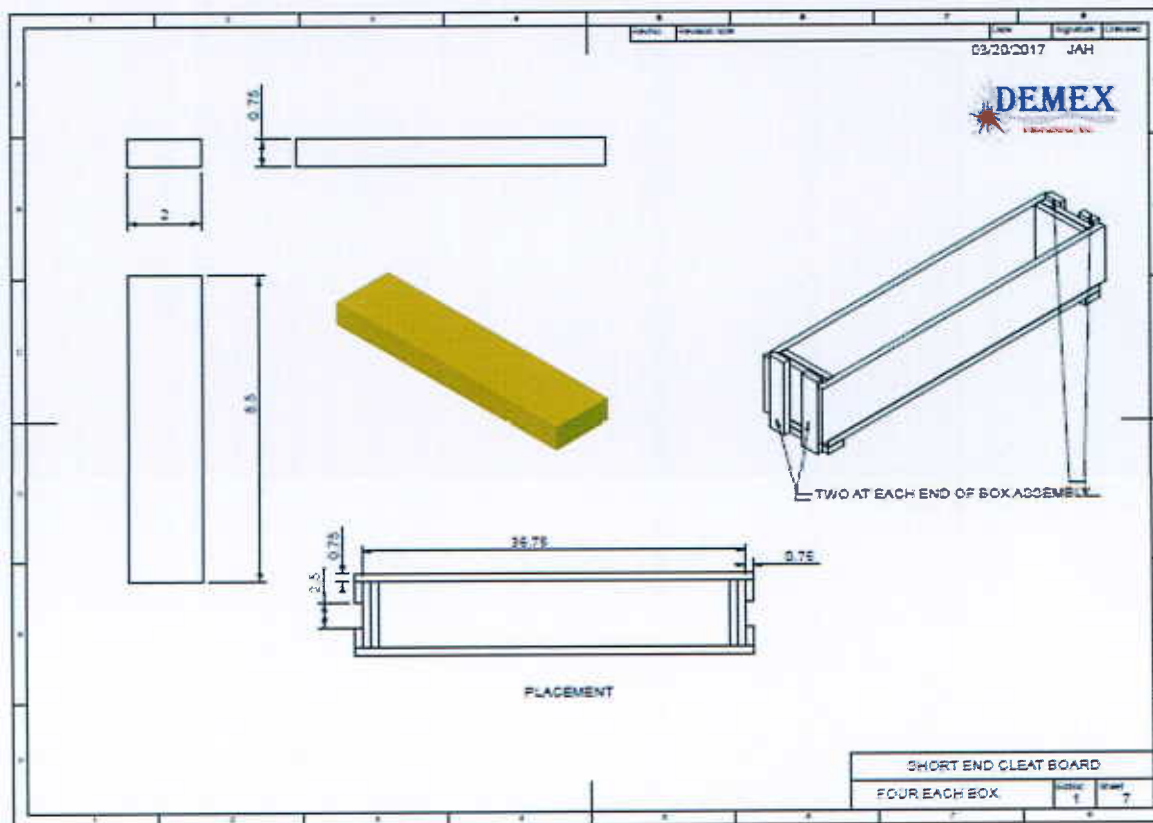
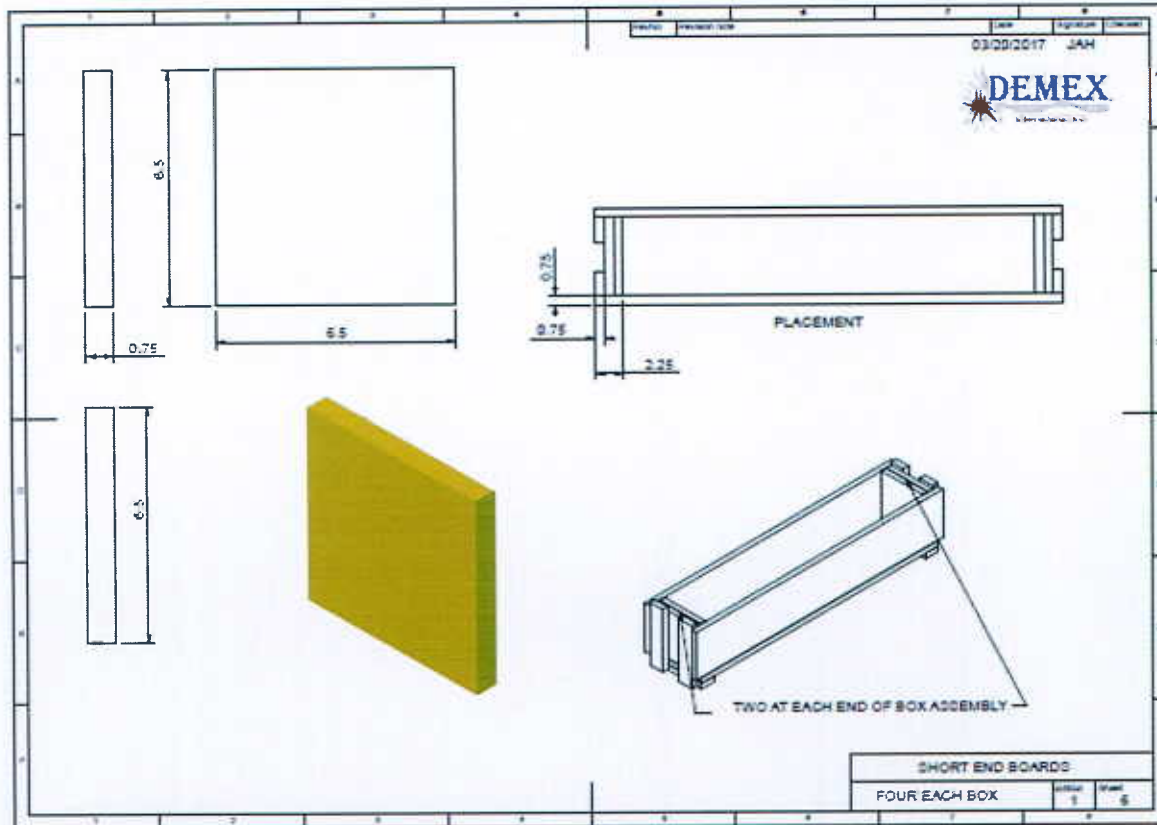

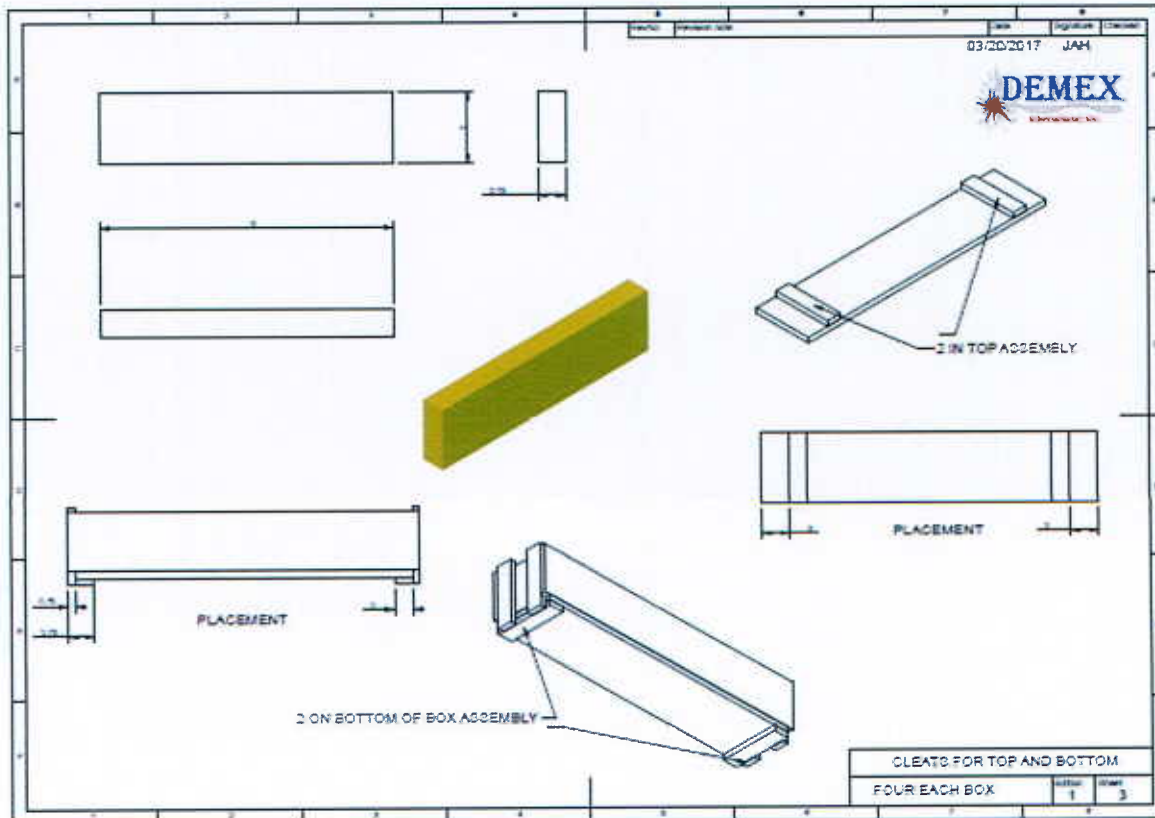
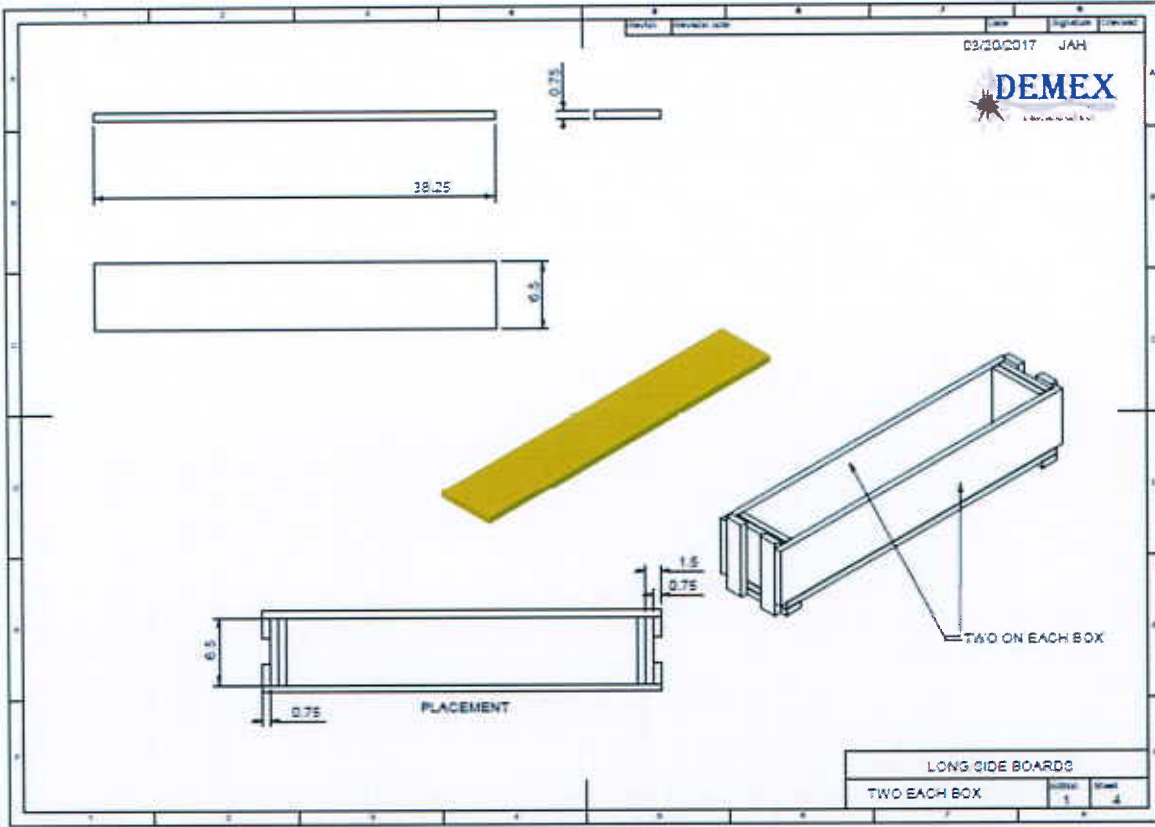

**UPS Bubble Roll - 12" x 300', 3/16", Perforated**



**SINGLE ROLLS**

Single rolls are recommended for medium volume users.

- Industrial duty bubble has a light nylon barrier for short ship cycles.
- For lightweight and semi-rugged items.
- Perforated every 12".

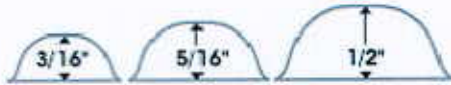

MODEL NO.	BUBBLE SIZE	ROLL SIZE	LBS./ROLL	PRICE PER ROLL				ADD TO CART	
				1	3	6	10+		
S-2501P	3/16"	12" x 300'	4	\$27 per roll any quantity				1	ADD

## Appendix A - Test Equipment and Instrumentation

Instrument or Equipment	Manufacturer	Model Number	Serial Number
Drop Tester	LAB	AD500-48	291045
Gram Scale	Mettler Toledo	PG4002-S	1122253714
Electronic Scale	American Scientific Products	TL-1600S	19538
Pressure Gauge	Cal Labs	0-30psi	BFG-01
Vibration Table	LAB	1250SVMC	8120128
Burst Tester	Perkins-Mullen	1000	12293
Compression Tester	Tinius-Olsen	Electromatic	62560
Torque Tester	Secure-Pak	Digital	D-928
Digital Micrometer	Mitutoyo	Digimatic	29376130
Mechanical Micrometer	Mitutoyo	MIC	LFM-1
Puncture Tester	TMI	A942	A942
Conditioning Chamber #2	Midwest Labs	922A	55455
Conditioning Chamber #6	Thermotron	SM-16C	23409
Conditioning Chamber #12	Thermotron	SM-16C	23408
Conditioning Chamber #16	Thermotron	SM-32C	42371

Calibration reports, certifications or additional information available upon request.

## Appendix B - Definitions / Abbreviations / Conversions

### Definitions

**Proprietary** – Customer was unable to obtain the required data or the MFG refused to provide this data due to trade secrets.

### Abbreviations

**MD**-Machine direction

**CMD**-Cross direction

**N/A**-Not applicable

**N/T**-Not tested

**NI**-Not indicated

**DNA**-Does not apply

**MSF**-1000 square feet

**B/A**-Board analysis

### Conversions

1 gallon water = 8.35 lbs.

mm = inches x 25.4

kg = lbs. / 2.205

1 ounce = 28.35 grams

meters<sup>3</sup> = ft<sup>3</sup> \* 0.02831

floz = 29.57cc \* floz

mils = inches / 0.001

inches = meters x 39.37

feet = meters \* 3.28083

lbs. = grams / 453.6

gal = liter / 3.785